



Water sustains life,
ours sustains a lifestyle.



Water Dispensers and Filtration Solutions

Product Guide 2024VS01



Contents:

1. Water Dispensers
2. Water Filters
3. Scheduled Services
4. Emerging Trends
5. Equipment Selection Form.

Water Cooling Solutions

Freestanding Water Coolers
Counter Top Water Coolers

Free Standing – Pure Water Coolers

PWC5280

PWC5280-W (White)



PWC5280 - Commercial 2-Temp Point-of-Use dispensers

- Two temperatures – **Hot** and Cold (PWC 5281 is Cool/Cold)
- Tomlinson dispensing valves (made in USA)
- Uses high-quality Panasonic or LG compressor
- G.A. Murdoch tubing (USA)
- Food-Grade 304 stainless steel hot and cold tanks
- Dual mechanical floats insure shut-off when full
- No electronics or solenoid to service
- Can be converted from bottle-less to bottled in the field
- No-dribble Easy-Lever faucets with hot safety lever
- 8.5" fill area allows larger cups, mugs or reusable bottles
- Removable drip-tray is dishwasher safe
- One-piece blow-molded high-density polyethylene cabinet that is scratch, dent and UV resistant for long life
- Available in Back or White
- Meets Energy Star 2.0 requirements

Specifications

Weight: 33 lb. .
Dimension: 12.5" W x 13" D x 37" H
Cold tank volume 1 gal
Hot tank volume .32 gal
Cooling Rate: 1.5 gal/hr 37-50 °F

Heating Rate: 1.3 gal/hr 180 °F
Voltage: 115 VAC
Power Required: 600w max
*Meets Energy Star Requirements
ADA compliant*



Vertex Water Products CF-5280.1

Counter Top - Vertex PureChill PWC450



The newest VERTEX Pure Water Coolers uses PureChill™ Technology to eliminate the need for an open reservoir for cold water storage. This hot and cold bottle-less water cooler closed system keeps environmental contaminants out so there is no need for costly in-tank sanitization. The water is safely dispensed directly to your cup.

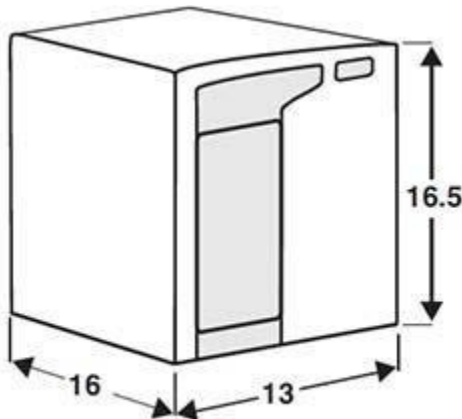

Dimensions (inches)

PureChill™ Technology

No need for expensive UV and Ozone in tank sanitizers Integrated Filter Monitor ensures freshly filtered water

ProTekk™ Auto Safety-Shut-Off Valve provides peace of mind

Two temperature system

Cold: 37-50° F, Adjustable - Hot: 180° F Autocontrol

LED indicator for Hot and Cold water on the front panel

Larger fill opening allows larger cups or reusable bottles
Hygienic dispensing touch pad control with no-touch dispensing faucet

Easy to clean control panel

Individual on/off control switches for cold and hot water on rear panel

Multi-Function Drink Stations

Water Cooling and Filtration units featuring;

*Sparkling Water

ION – TS Water Station



1. InstaChill™

Every glass is freshly filtered and instantly chilled in a Sealed Water Pathway where air never contacts the water supply.

2. Cooling Capacity

Dispense an 8-ounce glass of water every 30 seconds, for an hour ... and ION makes sure it's 42°F or colder. No other cooler even comes close.

3. Rapidhot™

Tea, cocoa, and even instant soups are delicious with piping hot, freshly filtered water. Up to two gallons per hour, convenient and ready whenever you are.

4. Sparkling Water

Indulge your healthy lifestyle with the healthy alternative to soft drinks. Refreshing with juice, or a twist of lemon or lime.

5. Quick Filter Changes

A simple twist to remove the filter, without any tools ... even without turning off the water supply.

6. Energy Savings Mode

Why run an appliance when no one is using it? Schedule ION's Sleepmode™ to reduce energy consumption anytime, anywhere.

7. Touchscreen Technology

Easy to use Touchscreen allows users to customize settings, and provides maintenance reminders.

8. SodaPro Regulator

Optional feature for easy to change CO2 supply. Provides up to 250 8-ounce glasses.

ION Microprocessor Control

Proprietary software and precision sensors deliver exact temperature control and ensure high performance under extreme conditions.



Beverage Grade CO2 is sold separately and equates to about 1 cent per ounce when using the Soda Pro easy change cylinders, or .3 cents per ounce when using the 10lb cylinders. Co2 cylinders are replaced as needed. Only SodaPro and Approved ION Bulk Cylinders are licensed for use in the ION TS Water Systems.



DOZENS OF STILL & SPARKLING FLAVORS

Choose your favorite from peach tea to coconut, and many from your favorite brands like AriZona.

Healthily hydrate: zero to low sugar, no artificial preservatives and many flavors have vitamins and minerals to keep you performing your best.

Alpine Start.



**.SUPER.
NATURALS
BY
LAVIT**

EBOOST

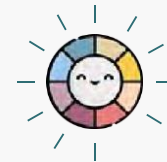

SAFETY FIRST

Automatic self sanitizing, Lavit set a new standard for beverage dispensers.

Lavit is made with antibacterial and antimicrobial materials, reducing the risks of standing water.



SPACE SAVING

Lavit's flavors come in compact, 100% recyclable aluminum EcoCaps, each takes 5X less space than packaged drinks. That means more shelf space and more flavor. It's a win-win.





CELSIUS



This signature rich, juicy flavor of oranges comes with B and C vitamins, Green Tea Extract, and Guarana Seed Extract for extra energy!



LAVIT ORIGINALS



Need a boost? Say goodbye to gross and harsh energy drinks and hello to renewable energy! Full of vitamins and minerals to keep you going.

EBOOST ↗



Amp your focus with a delicious mix of vitamins, electrolytes, antioxidants, nootropics, and natural caffeine. With 100% daily value of D, B12 and Zinc, you will feel the difference.

Get dozens of flavors on tap. Now available from Lavit.



Hi, I'm Bevi

The smart water cooler—bringing flavors, fizz, and eco-friendly fun to your workplace.



Still or sparkling?

Bump up the bubbles or stick with the classic. Choose from still, light sparkling, or sparkling for the right amount of fizz.

We're hot and we're cold

Select the temperature you're in the mood for—cold, ambient, or hot. Try hot water to make tea, then come back for a cold glass of sparkling water.

Top it off with an enhancement

Add up to 2 enhancements, like Immunity or Caffeine, into every beverage.

What's your flavor?

Choose from over 12 natural flavors, mix up to 3 at once, and adjust flavor strength to create your custom combination.

Know what's in your beverage

Quickly see the calories, sugar, and caffeine levels in your beverage as you dispense.

See your impact

Use the "Explore" tab to see your environmental impact, bottles saved counter, flavor ingredients, and more!



Bevi – Spec's

Different flavors of Bevi

We are constantly searching for the best-tasting flavors out there. Speak to your Bevi contact if there is a flavor below that you'd like to try.

Please check www.bevi.co for the latest list.



Refill station

Our machine accepts any container. With our single-nozzle design and LED lighting, filling up is clean and easy.

Touchscreen dispense

This is where a user selects their custom drink: still, sparkling, flavored, or not.

Water/power supply

- Standard 3-prong US 120V electrical outlet, draws less than 9 amps.
- 3/8" outer diameter water line.

Specifications

Dimensions	66"h x 16"w x 21.25"d
Weight	300 lbs.
Dispensing Height	12"
Water Options	Sparkling and cold still with and without added flavor and enhancements
Cooling Capacity	Unlimited
Hot Tank Capacity	0.79 gallon/3 liters
Rated Voltages/Frequency	115v/60Hz
Power Consumption	12 amps max



CO2 Supply for Sparkling Water

Sparkling Water Accessories

Cool, crisp, sparkling water is just moments away. Easily add a refillable CO2 tank with a regulator and you're ready to experience the endless bubbly refreshment that is the fastest growing trend in cold beverages!

CO₂ Tanks

- 14.5oz Soda Pro or Soda Stream
Carbonates up to 250 – 8oz Glasses (Approx. 1 cent per ounce)
Ion Touch Series and Soda Stream Systems Only
- 10 lb. CO₂ Aluminum Cylinder
Carbonates up to 3000 – 8oz Glasses (Approx. 0.3 cents per ounce)
Ion 900 Series, Ion Touch Series, Follet and Bevi Systems

CO₂ Regulator

Includes Wrench and Pressure Gauge.

CO₂ Cylinder Deposits

Soda Stream \$19.00

10lb Cylinder \$100.00

Deposits are charged upon installation



Under Counter Drink Stations

Water Cooling and Filtration units that are out of sight and water is dispensed at the sink via a separate faucet.

Under counter installations

Each under counter chiller is installed with a standard faucet.
Designer faucets are available.



Standard Feature Faucets \$75.00 each



Tomlinson Designer Faucets \$80-\$180 each



Tomlinson Contemporary Faucets \$80-\$180 each





Under Counter – B&O

t1

Minimal contemporary design,
maximum convenience and performance.

Durable and discreet, the T1's compact and flexible design can be installed directly into a countertop or placed above a sink, for the ultimate in filtered-water convenience.

At a glance.

Water options	 Chilled Sparkling Ambient
Configuration	 Integrated tap
Colour	 Black Steel
System	ProCore® Powerful and compact, energy-efficient modular system. DryChill® Rapid and hygienic, efficient chilling technology.
Technology	DeepSparkle® Sparkling water with long-lasting fizz Viovand® (optional) Chemical-free, eco-friendly integrated UVLED purification.
Hygiene	Totality® Filtration and hygiene assurance with Biomaster®.
Accessories	T1 Drip Tray Complementary circular tray for sinkless countertop integration.

Convenient and compact.

For complete convenience, the T1 can be mounted over a sink or paired with a discreet drip tray and placed directly into a countertop. Easily installed with a plug-and-play system, the illuminated control panel is seamlessly integrated into the body of the tap, providing versatile access to sparkling, chilled and ambient filtered water, making it fast and easy to refill bottles and glasses with refreshing, great-tasting water.

Confidently clean water.

Totality® is our 5-step methodology to achieving pure, healthier, premium water. Providing hygiene assurance in every pour, Totality® reduces sediment, odors, chlorine and microplastics, for freshly-filtered water that is safe to drink and tastes clean, crisp and fresh.

For complete peace of mind, select Viovand® enhanced UV-C purification. The ultraviolet LED technology provides eco-friendly, chemical-free sterilization to reduce bacteria and viruses.

Powerful and energy-efficient.

Designed and built in the UK, the T1 is powered by our exclusive, compact, modular ProCore® system with discrete ventilation. The integrated DryChill® airless, rapid cooling technology delivers the ultimate in hygiene and performance, reducing the risk of contamination and ensuring every glass delivers perfectly chilled, fresh-tasting water.

Bottleless water for every environment.

Designed with premium aesthetics for hard-working environments, the T1 features an easy-to-clean Fynil® finish and touch panel with antimicrobial silver ion protection. Refill with ease and eliminate the need for single-use plastic bottles, so you can hydrate with a conscience that is as clear as your water.

Sophisticated and versatile, suitable for both over-sink or sink-less environments.



Under Counter – Oasis R1

Oasis R1 Under counter chillers

The **Oasis R1P** water chiller will produce chilled water at a rate of approximately 1 gallon per hour. It has a stainless steel storage tank and is certified to NSF/ANSI Standard 61 Annex G (lead-free). The R1P is air-cooled and designed to fit conveniently under a sink. Upgrade from your old water chiller and get switched to the Oasis R1P Water Chiller for cooler, more refreshing drinking water.

NSF Certified. The Oasis R1P Water Chiller is certified by NSF to meet Standard 61 Annex G for lead-free content. NSF Certification is a third-party certification that assures this product complies with strict standards for quality and safety.

Certified Lead-Free. The Oasis R1P Water Chiller is certified lead-free according to the ANSI Standard 61 Annex G and uses 1/4" O.D. stainless steel tubing connections, and a powder-coated galvanized steel cabinet with plastic front.

Compact Air-Cooled Design. This chiller is made to fit and install easily under your sink, making it an easy and convenient appliance to have in your kitchen.

It also comes with a 4 ft. insulated power cord with NEMA 5-15 plug for easy installation.



Water Filtration Solutions

Benefits of Commercial Water Filters

Some of the many benefits of maintaining high-quality water through the use of Omnipure's line of commercial filters include:

Eliminate Energy Inefficiencies with Scale-Reduction Filters

It is a well-known fact that hard water can wreak havoc on commercial kitchen equipment. Scale deposits can cause frequent clogs and lead to unnecessary downtime. A quality commercial water filter will fight lime-scale buildup, eliminating time-consuming breakdowns and expensive repairs.

Less Equipment Maintenance

Many of our filters only take a few seconds to change, with no need for a service call or a costly disruption to regular business. Harmful contaminants can jeopardize your plumbing system, leading to expensive repairs. Commercial filters will keep kitchen equipment running efficiently while providing a steady source of clean water.

Reduction of Suspended Solids

One way of gauging water quality is to test the amount of microscopic solid particles that remain suspended in the water. A commercial water filter will reduce the number of suspended solids, resulting in a better appearance and taste.

Removal of Municipal and Groundwater Contamination

Many impurities such as VOCs, THMS, pesticides, chlorine, herbicides, and bacteria in water come from municipal and groundwater contamination. Using a commercial water filter will allow for contaminant-free water with no smell and tastes good every time.

Greater Treatment Efficiency

Commercial water filters can accommodate a much greater capacity than residential filters, offering greater treatment efficiency. Further, water filtration systems can be added to existing systems to further boost efficiency.

Chlorine-Free and Chemical-Free Filtered Water

Having high-quality water that is safe for consumption is essential in foodservice operations. Not only beverages, but many foods, require chemical-free water to ensure a proper taste. Omnipure filters will remove chlorine, leaving water fresh and better tasting.



NSF Certified Water filters you can trust

Omnipure Filter Company revolutionized the water filtration industry by making the first small disposable inline carbon filter. With the simple concept of “better tasting water,” the best inline water filter in the world was born. Our products are proudly manufactured in Caldwell, Idaho USA and distributed worldwide.

All Omnipure filter bodies are made with virgin, high-impact polypropylene which is especially ideal for use in applications where sanitary conditions are required. All materials of construction are NSF and/or FDA approved.



Omnipure 1250

\$19.95/Month

Flow Rate	0.5 gpm
Maximum Operating Pressure	125 psig
Operating Temperature	35 to 100 °F
Rated Capacity	1,250 gal/6 Months
Reduction Claim	Chlorine, taste, color, and odor reduction with scale/corrosion inhibitor
Standards	NSF (National Sanitation Foundation)

Omnipure ELF -

\$29.99/Month

Omnipure has developed an entire series of carbon blocks to work in the extra large ELF filter body. The omnipureBlocks™ available in the ELF-Series include Standard 10 and 1 micron carbon blocks, lead-specific carbon blocks and polyphosphate / carbon blocks for equipment protection from contaminants associated with hard water.

Gold Seal Reverse Osmosis - \$29.95/month

The Water Quality Association (WQA) Gold Seal represents the most credible and independent testing and validation entity in the water industry. The WQA's Gold Seal represents quality assurance through comprehensive testing and continuous research and evaluation of water treatment technologies.



The PuROTwist 4000 REVERSE OSMOSIS

semi-permeable membrane rinses contaminants to the drain. High quality, filtered drinking water is produced and conveniently stored in a sealed tank. The PuROTwist 4000 lead-free faucet easily delivers an abundant supply of clear, clean, and fresh drinking water to you and your colleagues.

Stage 1. *5 Micron Sediment Filter* : Removes dirt, sediments, sand, and other physical particles.

Stage 2. *Pre Carbon Filter* : Provides protection to the RO membrane from free chlorine and sediment.

Stage 3 *Reverse Osmosis Membrane* : Membrane reduces a high percentage of dissolved inorganics.

Stage 4 *Post Carbon Filter* : A final polishing process that enhances and clarifies your drinking water.

Our Services

Water Line Management

Expanding operator beverage menus mean more equipment than ever is being used in office and foodservice operations today. New equipment and an increasing number of beverage lines creates challenges for facilities teams in that both also mean more water lines to manage, and additional time required to identifying and trace those lines during service.

In offices Lunch rooms and Corporate break areas these days it is not uncommon to find:

- New beverage lines tangled with old lines.

- Poor or no identification of lines.

- No shut-off valves on lines.

- Hard-plumbed lines with little or no flexibility.

This can lead to:

- Time needlessly spent trying to identify lines and trace them back to the equipment.

- More time spent on a project than required or desired, leading to increased cost if it can't be billed back to the operator.

The Coffee Connection makes water line management easier for you with our John Guest quick connect plumbing fittings and ID tags.

We remove all previous vendors tubing and this cleans up unsightly mess of tangled water lines, organizing both under counter, in ceiling and exposed tubing within your location for improved appearance and maintenance efficiency. Offers quick line shut-off in case of unexpected equipment or line leaks. Reduces mistakes and spend less time spent identifying and tracing lines, plus easily shut lines off for servicing. Efficient water line serviceability reduces total equipment downtime during servicing. Easily modify system to meet changing plumbing requirements. Flexible and expansion-capable; easily add new beverage equipment in the future using your existing system. Minimal footprint and a variety of configurations available to meet your specific needs

Water Filter Management

How often should I my cartridges be changed?

In order for our filters to perform as represented and to provide the best quality water possible, it is essential that filters be replaced periodically. We recommend replacing your filter cartridge when capacity is reached or at least once every two years. The frequency of filter changes depends upon your water quality and your water usage. For example, if there is a lot of sediment and/or particles in your water, then you will have to change your filters more frequently than someone does with little to no sediment. Be sure to replace your filters whenever you notice a decline in the performance, whether it is a drop in flow rate and/or pressure or an unusual taste in the water.

The Coffee Connection has a offers scheduled services and will monitor your filter in multiples of 6 months based on the sizing of your account. If your employee bases has grown tremendously contact us so that we can resize your usage to ensure appropriate replacement schedules.

Why does my cartridges seem to slow the flow of water each month?

Because our cartridges are designed to remove contaminants and particles from the water, the cartridges will eventually plug as particles and contaminants are being captured. Therefore, plugging indicates that the cartridges are working efficiently an are removing containments.

Why does the service technician flushed a bunch of water down the drain when installing my filter?

All carbon-based filters need to be flushed to remove any excess carbon fines that are inside the cartridges. New cartridges are filled with air; therefore, flushing also removes the air from inside the cartridges and replaces it with water. The flushing process will allow any carbon-based cartridge to function at optimum levels without affecting any equipment that may be attached.

Sizing Chart for Water Filters replacement

Number of Staff using the water cooler	Liters Consumed daily. Based on drinking *750ml	Volume in liters consumed each year. *250 workdays	Suggested BevGuard Water Filter	Required Replacement schedule	Preventative Replacement and Service Plan
5	3.750	938	BevGuard 1200s	13 years	Annually
10	7.500	1875	BevGuard 1200s	6 years	Annually
15	11.250	2813	BevGuard 1200s	4 years	Annually
20	15.000	3750	BevGuard 1200s	3 years	Annually
25	18.750	4688	BevGuard 1200s	2 years	Annually
30	22.500	5625	BevGuard 1200s	2 years	Annually
35	26.250	6563	BevGuard 1200s	Annually	Annually
40	30.000	7500	BevGuard 1200s	Annually	Annually
45	33.750	8438	BevGuard 1200s	Annually	Annually
50	37.500	9375	BevGuard 1200s	Annually	Annually
55	41.250	10313	BevGuard 1200s	Annually	Annually
60	45.000	11250	BevGuard 1200s	Annually	Annually
65	48.750	12188	BevGuard 1200s	Annually	Annually
75	56.250	14063	BevGuard 3200s	7 Years	Annually
80	60.000	15000	BevGuard 3200s	7 Years	Annually
85	63.750	15938	BevGuard 3200s	6 Years	Annually
90	67.500	16875	BevGuard 3200s	6 Years	Annually
95	71.250	17813	BevGuard 3200s	6 Years	Annually
100	75.000	18750	BevGuard 3200s	5 Years	Annually

*Daily consumptions are based on 3 - 250ml servings per employee.

*Volume in liters consumed each year are based on 50, five day workweeks per employee

Equipment Selection Form

Equipment Selection Form.

Please detail below your water cooler and filtration selections.

Customer Name:

Address:

Contact Name:

Phone #:

Designation	Manufacturer	Model	Monthly Rental	QTY	R
Under Counter	Borg & Overstrom	T1	\$ 199.00		Select water filter
Under Counter	Oasis	R1	\$ 25.00		Select water filter
Free Standing	Vertex	BW5281 Cool and Cold	\$ 15.00		Select water filter
Free Standing	Vertex	BW5280 Hot and Cold	\$ 20.00		Select water filter
Counter Top EXEC	Vertex	PWC 450/900	\$ 30.00		Select water filter
Multi Function	Lavit	Cold Still / Cold Sparkling	\$ 65.00		Select water filter
Volume Rated					
Water filtration	BevGuard / Omnipure	1200+ Gallons	\$ 19.95		Select dispenser
Water filtration	BevGuard / Omnipure	3200+ Gallons	\$ 24.95		Select dispenser
Water filtration R.O.	PuRO Twist	PuROtwist 4000	\$ 29.95		Select dispenser
Water Softening	ELF - Omnipure	700+ grains	\$ 29.95		Select dispenser
All in One Systems contain the water filtration internally and the fixed cost includes both the Appliance and the water filtration system.					
Multi Function	ION TS 400	Hot/Cold/Ambient/Sparkling	\$ 105.00		Water Filter included
Multi Function	BEVI – G2	Full Sized Stand Up – 8 selections	\$ 399.99		Water Filter included
Multi Function	BEVI – Counter Top	Counter Top Unit – 4 Selections	\$ 349.99		Water Filter included
Labour, Products and Ongoing Maintenance					
CO2 Supply	SodaPro 14.5oz Cylinder	Beverage Co2 – 300 Cups	\$ 25.00 / Exchange		Deposit \$20.00
CO2 Supply	Lavit 24oz Cylinder	Beverage Co2 – 300 Cups	\$ 40.00 / Exchange		Deposit \$35.00
CO2 Bulk Supply	10lb Cylinder	Beverage Co2 – 3000 Cups	\$ 175.00 / Exchange		Deposit \$200.00
Installation	TCC	New / Move / Additional	Included in rental fee		No charge
Cleaning / Maintenance	TCC	Annually	Included in rental fee		No Charge
Cartridge Replacement	TCC	Annually	Included in rental fee		No Charge

--All in one-- --Select Filter-- ---Select your dispenser---